

# J1939 POWERCELL NGX

## Setup and Configuration Guide

### Table of Contents

|   |    |
|---|----|
| Overview .....                                | 2  |
| Warnings .....                                | 3  |
| J1939 POWERCELL NGX Technical Details.....    | 4  |
| POWERCELL NGX Installation Steps .....        | 5  |
| Mounting the POWERCELL NGX.....               | 5  |
| Supplying Battery Power.....                  | 5  |
| Wiring the Output Harnesses .....             | 6  |
| Installing Fuses.....                         | 8  |
| Connecting J1939 CAN Network.....             | 8  |
| Setting the J1939 POWERCELL NGX Address ..... | 10 |
| Inbound CAN Messages.....                     | 11 |
| Outbound CAN Messages.....                    | 13 |
| POWERCELL NGX Personality Glossary .....      | 15 |
| Track.....                                    | 15 |
| Soft-Start.....                               | 15 |
| Pulse Width Modulation (PWM).....             | 15 |
| Powering the System.....                      | 16 |
| Configuring the POWERCELL NGX.....            | 17 |
| Warranty Information.....                     | 22 |
| Contact Information.....                      | 23 |

## Overview

The Infinitybox J1939 POWERCELL NGX brings flexible multiplexed power distribution to any vehicle builder. Using standard J1939 PGN structures and commands, you can control the outputs on the POWERCELL NGX with practically any J1939 input device. In addition to high-current control, the POWERCELL NGX actively monitors the current flow from each output and reports that back on the J1939 network. These data can be used to monitor the status of the loads on your vehicle electrical system.

This document shows how to set up the J1939 POWERCELL NGX, wire it and details the PGN structure required to turn outputs on and off. It also details the CAN messages returned from the POWERCELL NGX.

## Warnings

THE INFINITYBOX J1939 POWERCELL NGX IS A FUSED POWER DISTRIBUTION MODULE FOR VEHICLES. PROPER CARE MUST BE TAKEN TO FUSE THE INPUT FEEDS TO THE CELL AND THE OUTPUT FEEDS FROM THE CELL. IMPROPER FUSE SELECTION CAN CAUSE DAMAGE TO THE VEHICLE ELECTRICAL SYSTEM RESULTING IN FIRE.

PROPER CARE MUST BE TAKEN TO ENSURE THAT POWER IS CORRECTLY APPLIED TO THE POWERCELL NGX. REVERSING POLARITY TO THE POWER AND GROUND FEEDS WILL CAUSE IRREPARABLE DAMAGE TO THE CELL AND WILL VOID THE WARRANTY.

## **J1939 POWERCELL NGX Technical Details**

System Operating Voltage: 9.0 to 30.0 VDC

Number of Outputs: 10

Output Type: High-Side Switched via MOSFETs

Maximum Current Rating per Output: 25-amps

Maximum Current Rating per POWERCELL NGX: 125-amps

PWM Capability: Outputs 1 through 8 can be dynamically pulse-width modulated

Internal Fusing: Standard Mini™ Fuse

Maximum Operating Temperature: 125 °C

Minimum Operating Temperature: -40 °C

# POWERCELL NGX Installation Steps

## Mounting the POWERCELL NGX

Mount the POWERCELL NGX on a suitable flat surface in the vehicle. Use the 4 mounting points in the corners of the cell and 1/4 -inch hardware. The recommended method to mount the POWERCELL NGX is to use 1/4-inch X 3/4-inch shoulder screws. If not using shoulder screws, take care as to not crush the mounting points by over tightening the screws.

In applications where the steady-state current draw out of the POWERCELL NGX exceeds 90-amps, mount the POWERCELL NGX in an area with adequate ventilation and with the fins of the heat sink running vertically.

## Supplying Battery Power

The POWERCELL NGX is designed to operate on 12 and 24-volt vehicle systems. It gets its power from the 3 circular Maxi-style connectors on the edge of the cell. Each of these connectors can accept up to 60-amps. The following table summarizes all the components for these connectors. The POWERCELL NGX input connectors use connector components from Aptiv, formerly Delphi. See the instructions from Aptiv for proper assembly and termination of these connector components.

The three power input connectors are electrically identical. You can use them in any order or combination. Based on the total current output of the POWERCELL NGX required, install 1 or 2 power feeds into the round Maxi-style connectors. Seal the third remaining connector with a POWERCELL NGX Sealing Plug (Infinitybox part number 869-026).

Table 1: POWERCELL NGX Input Connector Components.

|                                     |                | Aptiv Part Number |
|-------------------------------------|----------------|-------------------|
| POWERCELL<br>NGX Input<br>Connector | Connector/Seal | 12129387          |
|                                     | TPA            | 12129384          |
|                                     | Wire Seal      | 12129381          |
|                                     | Terminal       | 12129414          |

Each of the power feed wires to the POWERCELL NGX should be protected with a fuse located as closely to the battery source as possible. Size the fuse based on the gauge of wire feeding the POWERCELL NGX. Table 2 summarizes the proper fuse sizes for different wires.

Table 2: Maximum Fuse Ratings for Different Wire Gauges.

| AWG Size | Maximum Fuse Rating (Amps) |
|----------|----------------------------|
| 12       | 40                         |
| 10       | 50                         |
| 8        | 60                         |

## Wiring the Output Harnesses

The POWERCELL NGX output connectors use connector components from Aptiv, formerly Delphi. See the instructions from Aptiv for proper assembly and termination of these connector components. Table 3 summarizes all the connector and terminal components required to build custom wiring harnesses for your J1939 POWERCELL NGX.

Table 3: POWERCELL NGX Output Connector Components.

|   |                | Aptiv Part Number |
|---|----------------|-------------------|
| <b>POWERCELL<br/>NGX Output<br/>Connector</b> | Connector/Seal | 12110295          |
|   | TPA            | 12059195          |
|   | Wire Seal      | 12015323          |
|   | Terminal       | 12129493          |

Each output harness has one ground wire and 5 output wires. The ground wires should be 14-AWG and should be connected to the vehicle ground. It is important that the POWERCELL NGX is grounded to the chassis through a metal-to-metal connection. Make sure to remove all paint, powder coating, dirt and grease from the contact area.

The individual output wires should be properly sized to carry the output load. The maximum output current for a single POWERCELL NGX output is 25-amps. The total POWERCELL NGX can carry up to 125-amps. Exceeding these values will damage the cell and void the warranty.

Table 4 summarizes the details of the output harnesses by connector and cavity identification.

Table 4: POWERCELL NGX Output Harness Connector Details.

| Cavity ID | Connector A | Connector B |
|-----------|-------------|-------------|
| A         | GROUND      | GROUND      |
| B         | Output 10   | Output 1    |
| C         | Output 9    | Output 2    |
| D         | Output 8    | Output 3    |
| E         | Output 7    | Output 4    |
| F         | Output 6    | Output 5    |

Figure 1 identifies all the connectors on the J1939 POWERCELL NGX.

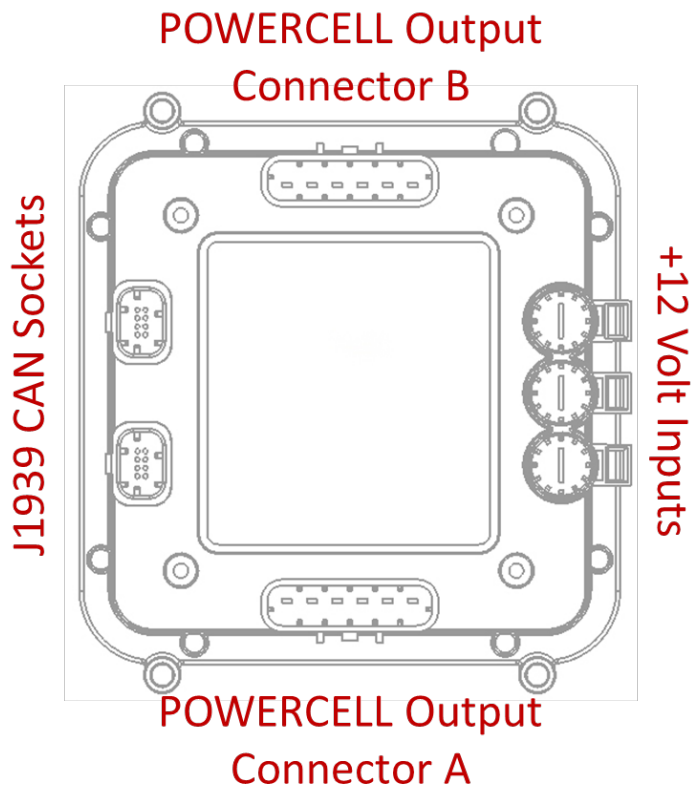

Figure 1: Socket Identification for J1939 POWERCELL NGX.

## Installing Fuses

The POWERCELL NGX has internal fuse holders to protect the output wires from short circuits and low-overloads. The holders are designed for a standard Mini™ automotive fuse. Select the rating of fuse to protect the smallest gauge of wire in the harness for each output. Table 5 gives recommendations on fuse ratings for different wire gauges.

Table 5: Maximum Fuse Ratings for Different Wire Gauges.

| AWG Size | Maximum Fuse Rating (Amps) |
|----------|----------------------------|
| 20       | 10                         |
| 18       | 15                         |
| 16       | 20                         |
| 14       | 25                         |

Use only OEM approved Mini™ fuses to protect the POWERCELL NGX outputs. There are numerous grey-market manufacturers of fuses that are unsafe and unreliable. Recommended manufacturers for these fuses are Littelfuse, Inc, Bussmann and Pacific Engineering.

## Connecting J1939 CAN Network

The CAN sockets on the J1939 POWERCELL NGXs connect the J1939 input device to the cells. These sockets provide + Battery power for the J1939 input device and the CAN HI & LOW connection for the J1939 network.

There are two CAN sockets on the POWERCELL NGX so that multiple J1939 POWERCELL NGX Cells can be connected on the same network. A CAN terminator plug with a 120-ohm resistor should be inserted into the last open CAN socket on the J1939 network. The two CAN sockets on a POWERCELL NGX are electrically identical so you can plug the CAN connector into either socket.



Table 6 shows the function, cavity identification and wire colors for the CAN connector. Connect the corresponding wires from the J1939 input device to these cavities in the connector.

Table 6: CAN Connector Wiring Details.

| <b>Cavity ID</b> | <b>Function</b> | <b>Standard Wire Color</b> |
|------------------|-----------------|----------------------------|
| <b>5</b>         | Ground          | Black                      |
| <b>6</b>         | CAN LOW         | Green                      |
| <b>7</b>         | CAN HIGH        | Yellow                     |
| <b>8</b>         | +Battery Power  | Red                        |

When building the J1939 network between the cells, the +Battery Power wires and the Ground wires should only go between the first POWERCELL NGX and the J1939 input device, if required. There should not be power and ground wires between the different J1939 cells in the network.

The J1939 POWERCELL NGX can supply a total of 1.0-amps out on the +Battery Power wire in the connector socket. If the total current draw for the J1939 input devices exceeds this limit, they must be connected to +Battery Power from a different source. This power feed is fused on the printed circuit board to protect against overloads and short circuits.

## Setting the J1939 POWERCELL NGX Address

Each J1939 POWERCELL NGX Cell must have its own unique address for the network to work correctly. The address is set by arranging jumpers in a binary pattern under the cover of the POWERCELL NGX. Figure 2 shows the location of the address headers on the POWERCELL NGX.

### LOCATING THE ADDRESS

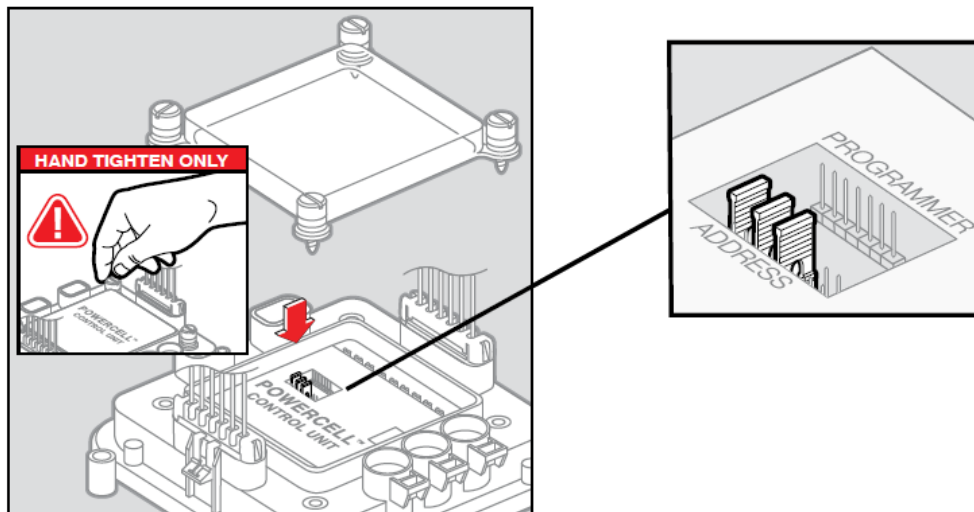

Figure 2: Location of the Address Headers on the J1939 POWERCELL NGX.

From left to right, the jumpers correspond to address values of 1, 2, 4 and 8. The POWERCELL NGX adds up the values of the missing jumpers to set the address. Figure 3 shows examples of different address settings with different jumper positions. Note that the POWERCELL NGX only learns its address upon power up. If the address headers are changed, power must be cycled so that it can relearn its address.

Figure 3 shows how to properly orient the jumpers on the headers to set the cell address.

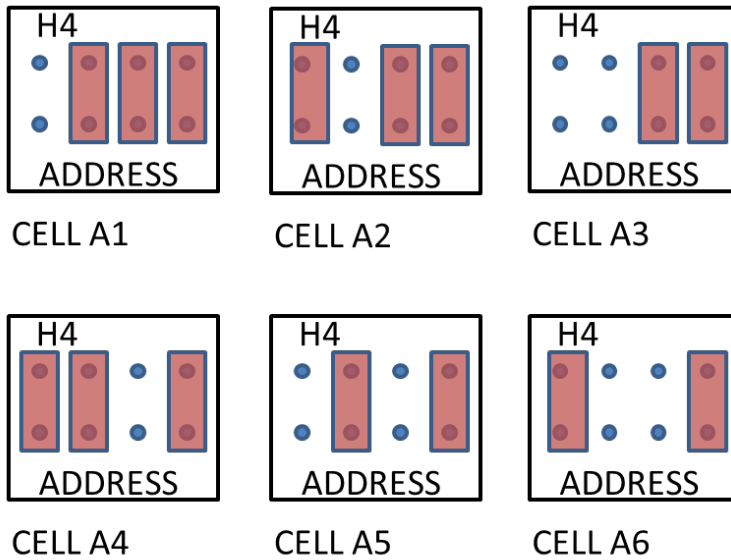

Figure 3: Correct Orientation of the Address Headers.

### Inbound CAN Messages

The POWERCELL NGX will respond to incoming PGN's per table 7. The default source address for the incoming message is 1E.

Table 7: Inbound and Outbound PGN's for different addresses settings.

| <b>Cell Address</b> | <b>Incoming PGN HEX</b> | <b>Reported Message 1-5 HEX</b> | <b>Reported Message 6-10 HEX</b> |
|---------------------|-------------------------|---------------------------------|----------------------------------|
| 1                   | FF01                    | FF11                            | FF21                             |
| 2                   | FF02                    | FF12                            | FF22                             |
| 3                   | FF03                    | FF13                            | FF23                             |
| 4                   | FF04                    | FF14                            | FF24                             |
| 5                   | FF05                    | FF15                            | FF25                             |
| 6                   | FF06                    | FF16                            | FF26                             |
| 7                   | FF07                    | FF17                            | FF27                             |
| 8                   | FF08                    | FF18                            | FF28                             |
| 9                   | FF09                    | FF19                            | FF29                             |
| 10                  | FF0A                    | FF1A                            | FF2A                             |
| 11                  | FF0B                    | FF1B                            | FF2B                             |
| 12                  | FF0C                    | FF1C                            | FF2C                             |
| 13                  | FF0D                    | FF1D                            | FF2D                             |
| 14                  | FF0E                    | FF1E                            | FF2E                             |
| 15                  | FF0F                    | FF1F                            | FF2F                             |
| 16                  | FF10                    | FF20                            | FF30                             |

Table 8 summarizes the control bits for the 10 outputs on a POWERCELL NGX. The first 10 bits control the 10 outputs in order. This personality is called track. The output state tracks the state of its control bit. If the first bit in the CAN message is 1, output 1 will turn on. If that same bit is set to 0, the output will be off.

The next 10 bits control the same 10 outputs except the outputs will soft-start when their control bit is set to 1. This feature gradually ramps up the current to the load over 500 ms. When the control bit is set to 0, the output will turn off.

The next 8 bits control outputs 1 through 8 through pulse-width modulation. There are 4 bits of PWM steps for each output which yields 16 steps. To set a PWM value on an output, a 1 must be written to its corresponding control bit and a duty cycle value must be written to the nibble that corresponds to the output in the 5<sup>th</sup>, 6<sup>th</sup>, 7<sup>th</sup> and 8<sup>th</sup> bytes.

In cases where multiple CAN messages are sent to control a single POWERCELL NGX output, there is a hierarchy of personalities. Track supersedes Soft-Start and PWM. Soft-Start supersedes PWM.

Table 8: Incoming J1939 Message Format.

|             |  | Byte 1               |       |       |       |                      |       |       |       | Byte 2               |       |            |            |                      |            |            |            | Byte 3               |            |            |            |                      |     |     |     | Byte 4               |     |     |     |                      |   |   |   |
|-------------|--|----------------------|-------|-------|-------|----------------------|-------|-------|-------|----------------------|-------|------------|------------|----------------------|------------|------------|------------|----------------------|------------|------------|------------|----------------------|-----|-----|-----|----------------------|-----|-----|-----|----------------------|---|---|---|
|             |  | 7                    | 6     | 5     | 4     | 3                    | 2     | 1     | 0     | 7                    | 6     | 5          | 4          | 3                    | 2          | 1          | 0          | 7                    | 6          | 5          | 4          | 3                    | 2   | 1   | 0   | 7                    | 6   | 5   | 4   | 3                    | 2 | 1 | 0 |
| Cell Output |  | 1                    | 2     | 3     | 4     | 5                    | 6     | 7     | 8     | 9                    | 10    | 1          | 2          | 3                    | 4          | 5          | 6          | 7                    | 8          | 9          | 10         | 1                    | 2   | 3   | 4   | 5                    | 6   | 7   | 8   |                      |   |   |   |
| Personality |  | Track                | Track | Track | Track | Track                | Track | Track | Track | Track                | Track | Soft-Start | Soft-Start | Soft-Start           | Soft-Start | Soft-Start | Soft-Start | Soft-Start           | Soft-Start | Soft-Start | Soft-Start | PWM                  | PWM | PWM | PWM | PWM                  | PWM | PWM | PWM |                      |   |   |   |
|             |  | Byte 5               |       |       |       |                      |       |       |       | Byte 6               |       |            |            |                      |            |            |            | Byte 7               |            |            |            |                      |     |     |     | Byte 8               |     |     |     |                      |   |   |   |
|             |  | 7                    | 6     | 5     | 4     | 3                    | 2     | 1     | 0     | 7                    | 6     | 5          | 4          | 3                    | 2          | 1          | 0          | 7                    | 6          | 5          | 4          | 3                    | 2   | 1   | 0   | 7                    | 6   | 5   | 4   | 3                    | 2 | 1 | 0 |
| Cell Output |  | 1                    |       |       |       | 2                    |       |       |       | 3                    |       |            |            | 4                    |            |            |            | 5                    |            |            |            | 6                    |     |     |     | 7                    |     |     |     | 8                    |   |   |   |
| Personality |  | 4-Bit PWM Duty Cycle |       |       |       | 4-Bit PWM Duty Cycle |       |       |       | 4-Bit PWM Duty Cycle |       |            |            | 4-Bit PWM Duty Cycle |            |            |            | 4-Bit PWM Duty Cycle |            |            |            | 4-Bit PWM Duty Cycle |     |     |     | 4-Bit PWM Duty Cycle |     |     |     | 4-Bit PWM Duty Cycle |   |   |   |

### Outbound CAN Messages

The POWERCELL NGX will respond with two CAN messages every cycle. The first message corresponds to the state of outputs 1 through 5. The second message corresponds to the state of outputs 6 through 10. The PGNs for these two messages are summarized in Table 7 above. Table 9 summarizes the data in these outbound messages.

Table 9: Format for Outbound CAN Messages

|             | Byte 1           |                  |                  |                  |                   |   |   |   | Byte 2          |   |   |   |   |   |   |   | Byte 3                 |   |   |   |   |   |   |   | Byte 4                |   |   |   |   |   |   |   |
|-------------|------------------|------------------|------------------|------------------|-------------------|---|---|---|-----------------|---|---|---|---|---|---|---|------------------------|---|---|---|---|---|---|---|-----------------------|---|---|---|---|---|---|---|
|             | 7                | 6                | 5                | 4                | 3                 | 2 | 1 | 0 | 7               | 6 | 5 | 4 | 3 | 2 | 1 | 0 | 7                      | 6 | 5 | 4 | 3 | 2 | 1 | 0 | 7                     | 6 | 5 | 4 | 3 | 2 | 1 | 0 |
| Cell Output | All              |                  |                  |                  |                   |   |   |   | 1 / 6           |   |   |   |   |   |   |   | 2 / 7                  |   |   |   |   |   |   |   | 3 / 8                 |   |   |   |   |   |   |   |
|             | Output 1/6 State | Output 2/7 State | Output 3/8 State | Output 4/9 State | Output 5/10 State |   |   |   | Current Monitor |   |   |   |   |   |   |   | Current Monitor        |   |   |   |   |   |   |   | Current Monitor       |   |   |   |   |   |   |   |
|             |                  |                  |                  |                  | X                 | X | X |   |                 |   |   |   |   |   |   |   |                        |   |   |   |   |   |   |   |                       |   |   |   |   |   |   |   |
|             | Byte 5           |                  |                  |                  |                   |   |   |   | Byte 6          |   |   |   |   |   |   |   | Byte 7                 |   |   |   |   |   |   |   | Byte 8                |   |   |   |   |   |   |   |
|             | 7                | 6                | 5                | 4                | 3                 | 2 | 1 | 0 | 7               | 6 | 5 | 4 | 3 | 2 | 1 | 0 | 7                      | 6 | 5 | 4 | 3 | 2 | 1 | 0 | 7                     | 6 | 5 | 4 | 3 | 2 | 1 | 0 |
| Cell Output | 4 / 9            |                  |                  |                  |                   |   |   |   | 5 / 10          |   |   |   |   |   |   |   | Cell Voltage           |   |   |   |   |   |   |   | Cell Temperature      |   |   |   |   |   |   |   |
|             | Current Monitor  |                  |                  |                  |                   |   |   |   | Current Monitor |   |   |   |   |   |   |   | Cell Voltage Broadcast |   |   |   |   |   |   |   | Cell Temperature in C |   |   |   |   |   |   |   |

The first 5 bits in the first byte broadcast the state of the outputs in the CAN message. If the bit is 1, the corresponding output is on. If the bit is 0, the corresponding output is off. In the first CAN message, these bits correspond to outputs 1 through 5. In the second CAN message, these bits correspond to outputs 6 through 10.

The next 5 bytes in the CAN message broadcast the real-time current flowing out of each output. In the first CAN message, these 5 bytes correspond to the current flow for outputs 1 through 5. In the second CAN message, these 5 bytes correspond to the current flow for outputs 6 through 10. Each count in these bytes represents 0.117 Amps of flow out of the output.

The 7th byte in the CAN message broadcasts the voltage as measured locally at the POWERCELL NGX. This value will be the same in both CAN messages broadcast by the POWERCELL NGX. Each count in this byte represents 0.125 Volts. This value can be used to monitor battery voltage at different locations on a vehicle’s electrical system.

The last byte in the CAN message broadcasts the temperature measured inside the POWERCELL NGX enclosure. This is broadcast in degrees Celsius using 2’s Compliment.

## POWERCELL NGX Personality Glossary

The J1939 POWERCELL NGX has a pre-configured library of personalities that define how the output reacts when it receives a J1939 command. The following list describes these different personalities and their behaviors.

### Track

Track is the most basic personality. The output tracks the state of the input. When the J1939 switch is pressed or latched into an ON position, it is broadcasting an ON command to the POWERCELL NGX output. That output will remain ON as long as the J1939 input device is broadcasting the ON command. When the J1939 input device broadcasts an OFF command, the POWERCELL NGX output turns OFF.

### Soft-Start

Soft-Start works in a similar way to Track. The output tracks the state of the input. When the J1939 switch is pressed or latched into an ON position, it is broadcasting an ON command to the POWERCELL NGX output. That output will remain ON as long as the J1939 input device is broadcasting the ON command. When the J1939 input device broadcasts an OFF command, the POWERCELL NGX output turns OFF. The difference is that the Soft-Start personality will ramp up current flow to the output over 500 ms. This is intended to limit the in-rush current to incandescent lamps and inductive loads.

### Pulse Width Modulation (PWM)

The Power outputs are controlled by solid-state MOSFETs. This allows the POWERCELL NGX to vary the amount of power coming out of an output by pulsing the output rapidly. This allows for easy control of light dimming, heater control and motor speed. The base frequency of the PWM pulse is 200 Hz.

## Powering the System

Once the J1939 input devices are properly set up and configured, connect the network to + Battery Power through the input harnesses to the cells. After 3 seconds, the system will be communicating with the J1939 input devices.

There is a blue LED located towards the center of the inMOTION Cell under the clear cover. This light indicates the status of communication on the network. When the system receives a packet of data on the J1939 network, the light will blink. It will also blink when the POWERCELL NGX broadcasts CAN messages. The default setting is every 250 ms.



## Configuring the POWERCELL NGX

The POWERCELL NGX can be easily configured over CAN by sending it specific messages. The following parameters can be set.

- The J1939 Data Rate (250 kb/s, 500 kb/s or 1 Mb/s)
- The Loss-of-Communications Timer (10, 20, 30 or 60 seconds)
- The Reporting Timer: (250, 500 or 1000 ms)
- The Loss-of-Com behavior for each output (Maintain State, Turn off or Turn on)
- Pulse-Width Modulation Frequency (200 Hz or 20 kHz)
- A User Assigned Configuration Designation (0 to 255)

The J1939 Data rate is the communication speed used on the J1939 network. The default data rate for the J1939 POWERCELL NGX is 250 kb/s. All nodes on the CAN network must be communicating at the same data rate for proper communication.

The POWERCELL NGX has the ability to manage the state of the outputs in case of a loss of communication with the rest of the CAN network. Examples of loss of communication could include damage to a CAN cable or failure of another CAN node on the J1939 network. If the POWERCELL NGX does not receive a valid J1939 CAN message for a period of time, you can select the behavior for each output on the POWERCELL NGX. The timer value can be set and the behavior for each output can be set individually.

You can also set the timer for how frequently the POWERCELL NGX broadcasts its status. The default setting for the reporting timer is once every 250 ms. You can optionally set this to 500 ms or 1000 ms if you want to decrease the amount of traffic on your network.

Additionally, the POWERCELL NGX can be polled to get its firmware revision, its present configuration state and the user assigned configuration designation.

The CAN ID for the message to set these parameters and to poll the POWERCELL NGX is FF4X using source address 63. The X designates the address set for that specific POWERCELL NGX. It will respond back using CAN ID FF5X, where the X designates the address for the specific cell.

The following table summarizes the CAN ID required to set the parameters and the CAN ID required to poll the POWERCELL NGX to get its parameters.

| Cell Address | Configuration CAN ID | Configuration Source Address | Polling Response CAN ID |
|--------------|----------------------|------------------------------|-------------------------|
| 1            | FF41                 | 0x63                         | FF51                    |
| 2            | FF42                 | 0x63                         | FF52                    |
| 3            | FF43                 | 0x63                         | FF53                    |
| 4            | FF44                 | 0x63                         | FF54                    |
| 5            | FF45                 | 0x63                         | FF55                    |
| 6            | FF46                 | 0x63                         | FF56                    |
| 7            | FF47                 | 0x63                         | FF57                    |
| 8            | FF48                 | 0x63                         | FF58                    |
| 9            | FF49                 | 0x63                         | FF59                    |
| 10           | FF4A                 | 0x63                         | FF5A                    |
| 11           | FF4B                 | 0x63                         | FF5B                    |
| 12           | FF4C                 | 0x63                         | FF5C                    |
| 13           | FF4D                 | 0x63                         | FF5D                    |
| 14           | FF4E                 | 0x63                         | FF5E                    |
| 15           | FF4F                 | 0x63                         | FF5F                    |
| 16           | FF40                 | 0x63                         | FF50                    |

The POWERCELL NGX configuration message must follow this format.

|          | Byte 1                          |       |   |   |   |   |   |   | Byte 2    |           |                 |     |           |       |       |       | Byte 3 |       |       |       |       |   |   |   | Byte 4 |   |   |   |   |                             |   |   |  |  |  |  |  |
|----------|---------------------------------|-------|---|---|---|---|---|---|-----------|-----------|-----------------|-----|-----------|-------|-------|-------|--------|-------|-------|-------|-------|---|---|---|--------|---|---|---|---|-----------------------------|---|---|--|--|--|--|--|
|          | 7                               | 6     | 5 | 4 | 3 | 2 | 1 | 0 | 7         | 6         | 5               | 4   | 3         | 2     | 1     | 0     | 7      | 6     | 5     | 4     | 3     | 2 | 1 | 0 | 7      | 6 | 5 | 4 | 3 | 2                           | 1 | 0 |  |  |  |  |  |
| Function | Configuration Confirmation Bits |       |   |   |   |   |   |   | Data Rate | LOC Timer | Reporting Timer | PWM | Frequency | LOC01 | LOC02 | LOC03 | LOC04  | LOC05 | LOC06 | LOC07 | LOC08 |   |   |   |        |   |   |   |   |                             |   |   |  |  |  |  |  |
|          | Byte 5                          |       |   |   |   |   |   |   | Byte 6    |           |                 |     |           |       |       |       | Byte 7 |       |       |       |       |   |   |   | Byte 8 |   |   |   |   |                             |   |   |  |  |  |  |  |
|          | 7                               | 6     | 5 | 4 | 3 | 2 | 1 | 0 | 7         | 6         | 5               | 4   | 3         | 2     | 1     | 0     | 7      | 6     | 5     | 4     | 3     | 2 | 1 | 0 | 7      | 6 | 5 | 4 | 3 | 2                           | 1 | 0 |  |  |  |  |  |
| Function | LOC09                           | LOC10 |   |   |   |   |   |   |           |           |                 |     |           |       |       |       |        |       |       |       |       |   |   |   |        |   |   |   |   | User Configuration Revision |   |   |  |  |  |  |  |

The Configuration Confirmation Bits must 0x99 to configure the POWERCELL NGX. This is the data byte that the cell must see to perform the configuration.

The J1939 Data Rate is set with the first two bits in the second byte. The following bit combinations set the data rate.

- 250 kb/s: 00
- 500 kb/s: 01
- 1000 kb/s: 10

The loss-of-communication timer is set with the next two bits in the second byte. The following bit combinations set value for the loss-of-communication timer.

- 10 Seconds: 00
- 20 Seconds: 01
- 30 Seconds: 10
- 60 Seconds: 11

The reporting timer is set with the next two bits in the second byte. The following bit combinations set value for the reporting timer.

- 250 ms: 00
- 500 ms: 01
- 1000 ms: 10

The base frequency for pulse-width modulation is set using the last two bits in the second byte. The following bit combinations set value for the PWM frequency.

- 200 Hz: 01
- 20,000 Hz: 10

The loss-of-communication behavior for each output is set using pairs of bits in the bytes defined in the figure above. Each POWERCELL NGX output can be set to keep its state, turn off or turn on if there is a loss of CAN communication to the cell and it exceeds the timer value set as the Loss-of-Com time. The following combinations of bits show how to set the loss-of-com behavior for each output.

- Maintain State: 00
- Turn Output Off: 01
- Turn Output On: 10

Lastly, a user defined configuration revision value can be assigned in the 8<sup>th</sup> data byte of the configuration message. This can be used to keep track of different POWERCELL NGX configurations and ensure that a cell is set up correctly. This can be set between 0 and 255.

To set the custom configuration for the POWERCELL NGX, set all the required parameters in a single J1939 CAN message per the information above. If the POWERCELL NGX receives a valid configuration message, the changes will be made and the cell will be held in reset until its power is cycled. You must remove power to the cell and reapply it. The changes will be effective when the cell is powered up again.

You can send a J1939 CAN message to the POWERCELL NGX to get a response with the current settings for these parameters. You will also get the configuration version in this message.

To check the settings on the POWERCELL NGX, send the same configuration message as you did to set it up. It should be FF4X from source address 63, where X corresponds to the set address of the cell. See the table above for more details. Enter 0x11 in the first data byte and leave the rest of the bytes as 0. The POWERCELL NGX will respond with a message in this format.

|          |           | Byte 1                          |   |   |   |   |   |   |   | Byte 2                          |   |   |   |   |   |   |   | Byte 3                                |   |   |   |   |   |   |   | Byte 4                         |   |   |   |   |   |   |   |
|----------|-----------|---------------------------------|---|---|---|---|---|---|---|---------------------------------|---|---|---|---|---|---|---|---------------------------------------|---|---|---|---|---|---|---|--------------------------------|---|---|---|---|---|---|---|
|          |           | 7                               | 6 | 5 | 4 | 3 | 2 | 1 | 0 | 7                               | 6 | 5 | 4 | 3 | 2 | 1 | 0 | 7                                     | 6 | 5 | 4 | 3 | 2 | 1 | 0 | 7                              | 6 | 5 | 4 | 3 | 2 | 1 | 0 |
| Function |           | Major Version in Decimal Format |   |   |   |   |   |   |   | Minor Version in Decimal Format |   |   |   |   |   |   |   | ADC Source In Decimal Format (4 or 5) |   |   |   |   |   |   |   | User Selectable EEPROM Version |   |   |   |   |   |   |   |
|          |           |                                 |   |   |   |   |   |   |   |                                 |   |   |   |   |   |   |   |                                       |   |   |   |   |   |   |   |                                |   |   |   |   |   |   |   |
|          |           | Byte 5                          |   |   |   |   |   |   |   | Byte 6                          |   |   |   |   |   |   |   | Byte 7                                |   |   |   |   |   |   |   | Byte 8                         |   |   |   |   |   |   |   |
|          |           | 7                               | 6 | 5 | 4 | 3 | 2 | 1 | 0 | 7                               | 6 | 5 | 4 | 3 | 2 | 1 | 0 | 7                                     | 6 | 5 | 4 | 3 | 2 | 1 | 0 | 7                              | 6 | 5 | 4 | 3 | 2 | 1 | 0 |
| Function | Data Rate | LOC Timer                       |   |   |   |   |   |   |   | Reporting Timer                 |   |   |   |   |   |   |   | PWM Frequency                         |   |   |   |   |   |   |   | LOC01                          |   |   |   |   |   |   |   |
|          |           |                                 |   |   |   |   |   |   |   |                                 |   |   |   |   |   |   |   |                                       |   |   |   |   |   |   |   |                                |   |   |   |   |   |   |   |
|          |           | LOC02                           |   |   |   |   |   |   |   | LOC03                           |   |   |   |   |   |   |   | LOC04                                 |   |   |   |   |   |   |   | LOC05                          |   |   |   |   |   |   |   |
|          |           |                                 |   |   |   |   |   |   |   |                                 |   |   |   |   |   |   |   |                                       |   |   |   |   |   |   |   |                                |   |   |   |   |   |   |   |
|          |           | LOC06                           |   |   |   |   |   |   |   | LOC07                           |   |   |   |   |   |   |   | LOC08                                 |   |   |   |   |   |   |   | LOC09                          |   |   |   |   |   |   |   |
|          |           |                                 |   |   |   |   |   |   |   |                                 |   |   |   |   |   |   |   |                                       |   |   |   |   |   |   |   |                                |   |   |   |   |   |   |   |
|          |           | LOC10                           |   |   |   |   |   |   |   |                                 |   |   |   |   |   |   |   |                                       |   |   |   |   |   |   |   |                                |   |   |   |   |   |   |   |
|          |           |                                 |   |   |   |   |   |   |   |                                 |   |   |   |   |   |   |   |                                       |   |   |   |   |   |   |   |                                |   |   |   |   |   |   |   |

The first three bytes hold information specific to the manufacturing process at Infinitybox. The fourth data byte holds the customer selected configuration revision number. The last 4 bytes hold the existing configuration of the POWERCELL NGX. The format of these bytes follows the format used to set the configuration.

Here is an example. Let's say that you want to configure a POWERCELL NGX that is addressed as 1 and you want these parameters:

- J1939 Data Rate: 250 kb/s
- Loss-of-Com Timer: 10 seconds
- Reporting Timer: 250 ms
- PWM Frequency: 200 Hz
- Loss-of-Com Behavior:
  - Output 1: Maintain State
  - Output 2: Maintain State
  - Output 3: Maintain State
  - Output 4: Turn Off
  - Output 5: Maintain State
  - Output 6: Maintain State
  - Output 7: Maintain State
  - Output 8: Turn Off
  - Output 9: Turn Off
  - Output 10: Turn Off
- A custom configuration number of 190 decimal (BE in Hex)

You would send the following J1939 CAN message using CAN ID FF4163.

|          |  | Byte 1                          |   |       |   |   |   |   |   | Byte 2    |           |   |   |   |                 |     |           | Byte 3 |       |       |       |       |       |       |                             | Byte 4 |   |   |   |   |   |   |   |
|----------|--|---------------------------------|---|-------|---|---|---|---|---|-----------|-----------|---|---|---|-----------------|-----|-----------|--------|-------|-------|-------|-------|-------|-------|-----------------------------|--------|---|---|---|---|---|---|---|
|          |  | 7                               | 6 | 5     | 4 | 3 | 2 | 1 | 0 | 7         | 6         | 5 | 4 | 3 | 2               | 1   | 0         | 7      | 6     | 5     | 4     | 3     | 2     | 1     | 0                           | 7      | 6 | 5 | 4 | 3 | 2 | 1 | 0 |
| Function |  | Configuration Confirmation Bits |   |       |   |   |   |   |   | Data Rate | LOC Timer |   |   |   | Reporting Timer | PWM | Frequency | LOC01  | LOC02 | LOC03 | LOC04 | LOC05 | LOC06 | LOC07 | LOC08                       |        |   |   |   |   |   |   |   |
| Binary   |  | 1                               | 0 | 0     | 1 | 1 | 0 | 0 | 1 | 0         | 0         | 0 | 0 | 0 | 0               | 0   | 1         | 0      | 0     | 0     | 0     | 0     | 0     | 0     | 1                           | 0      | 0 | 0 | 0 | 0 | 0 | 0 | 1 |
| Hex      |  | 9                               |   |       |   | 9 |   |   |   | 0         |           |   |   | 1 |                 |     |           | 0      |       |       |       | 1     |       |       |                             | 0      |   |   |   | 1 |   |   |   |
|          |  | Byte 5                          |   |       |   |   |   |   |   | Byte 6    |           |   |   |   |                 |     |           | Byte 7 |       |       |       |       |       |       |                             | Byte 8 |   |   |   |   |   |   |   |
|          |  | 7                               | 6 | 5     | 4 | 3 | 2 | 1 | 0 | 7         | 6         | 5 | 4 | 3 | 2               | 1   | 0         | 7      | 6     | 5     | 4     | 3     | 2     | 1     | 0                           | 7      | 6 | 5 | 4 | 3 | 2 | 1 | 0 |
| Function |  | LOC09                           |   | LOC10 |   |   |   |   |   |           |           |   |   |   |                 |     |           |        |       |       |       |       |       |       | User Configuration Revision |        |   |   |   |   |   |   |   |
| Binary   |  | 0                               | 1 | 0     | 1 | 0 | 0 | 0 | 0 | 0         | 0         | 0 | 0 | 0 | 0               | 0   | 0         | 0      | 0     | 0     | 0     | 0     | 0     | 0     | 1                           | 0      | 1 | 1 | 1 | 1 | 1 | 0 |   |
| Hex      |  | 5                               |   |       |   | 0 |   |   |   | 0         |           |   |   | 0 |                 |     |           | 0      |       |       |       | B     |       |       |                             | E      |   |   |   |   |   |   |   |

To confirm that your settings are correct, you would send a message from CAN ID FF4163 with 0x11 in the first data byte and 0x00 in the remaining bytes. This is the confirmation message that you will receive.

|          |  | Byte 1                          |           |   |                 |     |           |   |       | Byte 2                          |       |       |       |       |       |       |       | Byte 3                                |   |   |   |   |   |   |   | Byte 4                         |   |   |   |   |   |   |   |
|----------|--|---------------------------------|-----------|---|-----------------|-----|-----------|---|-------|---------------------------------|-------|-------|-------|-------|-------|-------|-------|---------------------------------------|---|---|---|---|---|---|---|--------------------------------|---|---|---|---|---|---|---|
|          |  | 7                               | 6         | 5 | 4               | 3   | 2         | 1 | 0     | 7                               | 6     | 5     | 4     | 3     | 2     | 1     | 0     | 7                                     | 6 | 5 | 4 | 3 | 2 | 1 | 0 | 7                              | 6 | 5 | 4 | 3 | 2 | 1 | 0 |
| Function |  | Major Version in Decimal Format |           |   |                 |     |           |   |       | Minor Version in Decimal Format |       |       |       |       |       |       |       | ADC Source In Decimal Format (4 or 5) |   |   |   |   |   |   |   | User Selectable EEPROM Version |   |   |   |   |   |   |   |
| Binary   |  | 0                               | 0         | 0 | 0               | 0   | 0         | 0 | 0     | 0                               | 0     | 0     | 0     | 0     | 1     | 1     | 0     | 0                                     | 0 | 0 | 0 | 0 | 1 | 0 | 0 | 1                              | 0 | 1 | 1 | 1 | 1 | 1 | 0 |
| Hex      |  | 0                               |           |   |                 | 0   |           |   |       | 0                               |       |       |       | 6     |       |       |       | 0                                     |   |   |   | 4 |   |   |   | B                              |   |   |   | E |   |   |   |
|          |  | Byte 5                          |           |   |                 |     |           |   |       | Byte 6                          |       |       |       |       |       |       |       | Byte 7                                |   |   |   |   |   |   |   | Byte 8                         |   |   |   |   |   |   |   |
|          |  | 7                               | 6         | 5 | 4               | 3   | 2         | 1 | 0     | 7                               | 6     | 5     | 4     | 3     | 2     | 1     | 0     | 7                                     | 6 | 5 | 4 | 3 | 2 | 1 | 0 | 7                              | 6 | 5 | 4 | 3 | 2 | 1 | 0 |
| Function |  | Data Rate                       | LOC Timer |   | Reporting Timer | PWM | Frequency |   | LOC01 | LOC02                           | LOC03 | LOC04 | LOC05 | LOC06 | LOC07 | LOC08 | LOC09 | LOC10                                 |   |   |   |   |   |   |   |                                |   |   |   |   |   |   |   |
| Binary   |  | 0                               | 0         | 0 | 0               | 0   | 0         | 1 | 0     | 0                               | 0     | 0     | 0     | 0     | 0     | 1     | 0     | 0                                     | 0 | 0 | 0 | 0 | 0 | 1 | 0 | 1                              | 0 | 1 | 0 | 0 | 0 | 0 |   |
| Hex      |  | 0                               |           |   |                 | 1   |           |   |       | 0                               |       |       |       | 1     |       |       |       | 0                                     |   |   |   | 1 |   |   |   | 5                              |   |   |   | 0 |   |   |   |

## Warranty Information

Infinitybox, LLC (“Infinitybox”) warrants against any defects in materials and workmanship to the Product’s modules, wiring harnesses and accessory modules for a period of one (1) year from the first date of purchase. Subject to the terms of this warranty described below, Infinitybox will replace any such defective Product that is returned to Infinitybox within the one (1) year period from initial purchase. Replacement of any defective part or Product will not extend the applicable warranty period.

The warranty does not apply to: (i) any Product that is not installed in compliance with the applicable Product documentation; (ii) any defect in, or failure of, the Product resulting from an accident, shock, negligence, water immersion or misuse; (iii) any Product that has been modified, adjusted, repaired, or disassembled by any party other than Infinitybox; or (iv) any defect other than in materials and workmanship.

This warranty covers only the original purchaser of Product purchased from an Infinitybox authorized dealer in the United States. In order to receive warranty service, purchaser must provide Infinitybox with a copy of the receipt stating the dealer name, product purchased and date of purchase. Products found to be defective during the warranty period will be replaced (with a product deemed to be equivalent or better) at the discretion of Infinitybox.

Infinitybox’s sole liability for any defective Product is limited solely to the replacement of Product pursuant to this warranty. Infinitybox reserves the right to replace any repairable parts with new or refurbished parts.

INFINITYBOX DISCLAIMS ALL OTHER WARRANTIES, WHETHER EXPRESS, IMPLIED OR STATUTORY, SUCH AS WARRANTIES OF MERCHANTABILITY AND FITNESS FOR PURPOSE. IN NO EVENT SHALL INFINITYBOX BE LIABLE FOR ANY PUNITIVE, INDIRECT, INCIDENTAL OR CONSEQUENTIAL DAMAGES, INCLUDING WITHOUT LIMITATION, LIABILITY FOR LOSS OF USE, LOSS OF PROFITS, LOSS OF PRODUCT OR BUSINESS INTERRUPTION HOWEVER THE SAME MAY BE CAUSED, INCLUDING NEGLIGENCE.

## Contact Information

Infinitybox, LLC  
6460 West Cortland Street  
Chicago, Illinois 60707  
(847) 232-1991  
[www.infinitybox.com](http://www.infinitybox.com)  
[sales@infinitybox.com](mailto:sales@infinitybox.com)