

**PRIMARY POWER DISTRIBUTION AND inRESERVE SOLENOID
(LOCATED ON PASSENGER FENDER)**

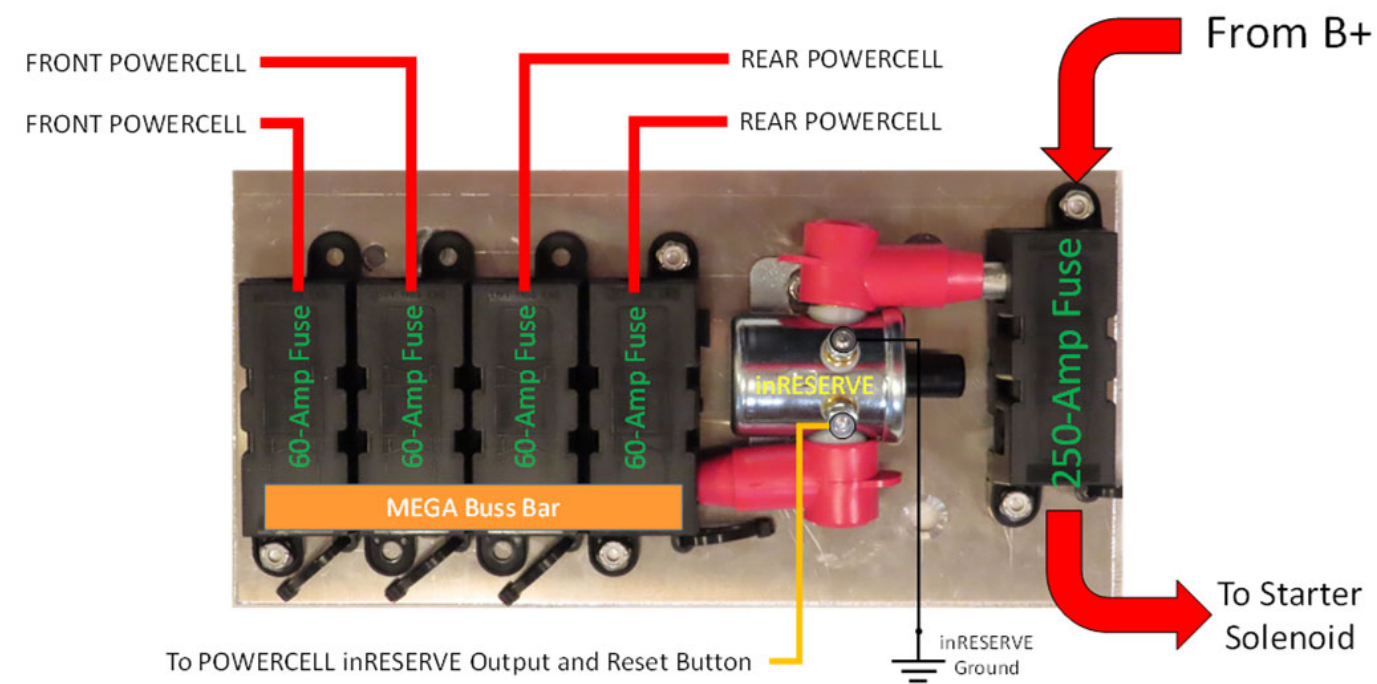

8-AWG Power Cables for Rear POWERCELL
Run Through Channel Under Passenger Doorsil

REAR POWERCELL
(LOCATED ON REAR PASSENGER FENDER)

MASTERCELL
(LOCATED IN GLOVEBOX)

8-AWG Power Cables
for Front POWERCELL
Run Under Top Lip of
Fire Wall

FRONT POWERCELL
(LOCATED ON INNER DRIVER FENDER)

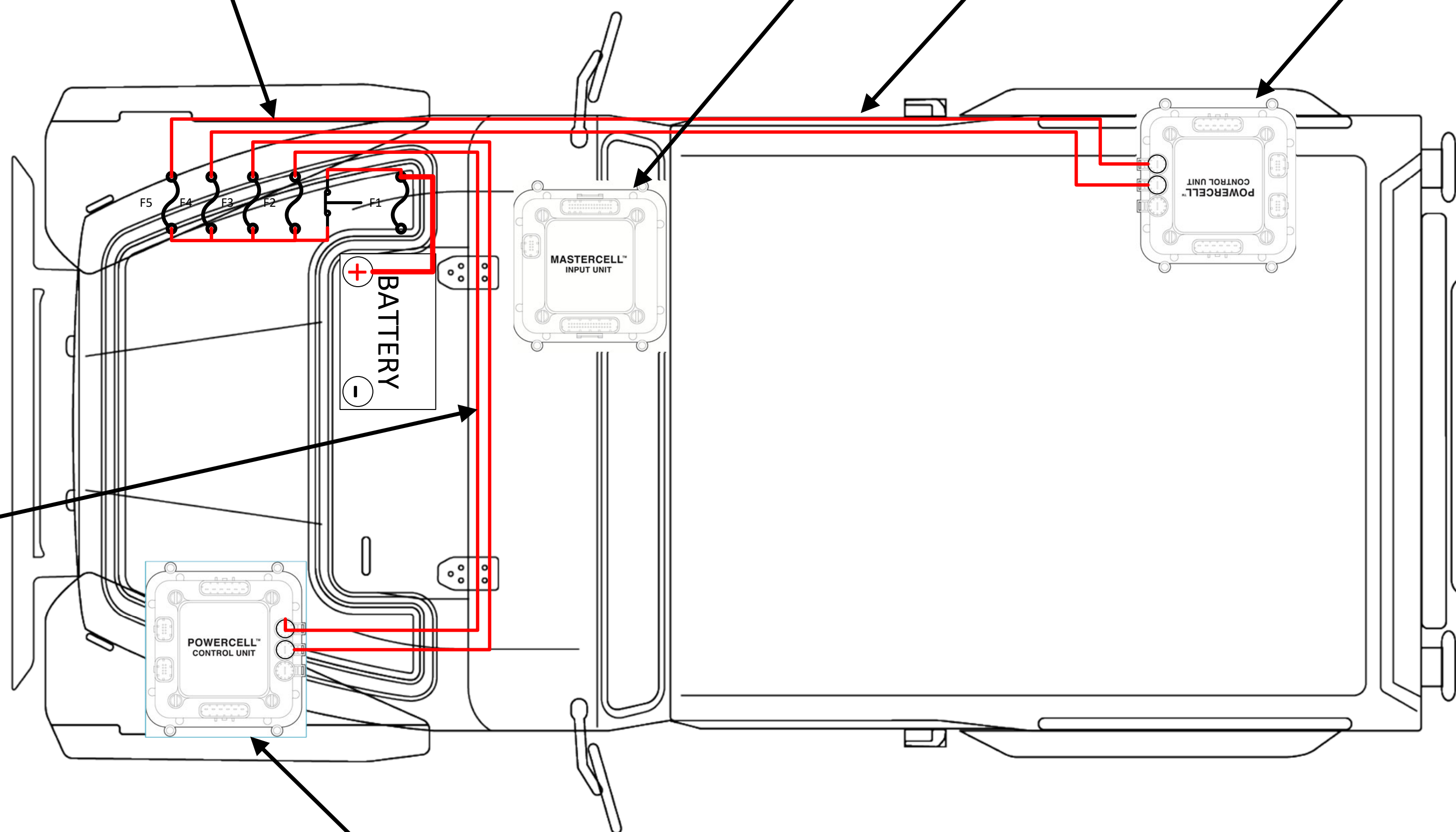

	INFINITYBOX, LLC			
	1979 Jeep CJ7 Cell Location and Primary Power Routing			
SIZE	FSCM NO	DWG NO	REV	
C		JEEP 01	A	
SCALE	N/A	SHEET	1 OF 1	