

## Wiring the Haltech Elite 950 ECU

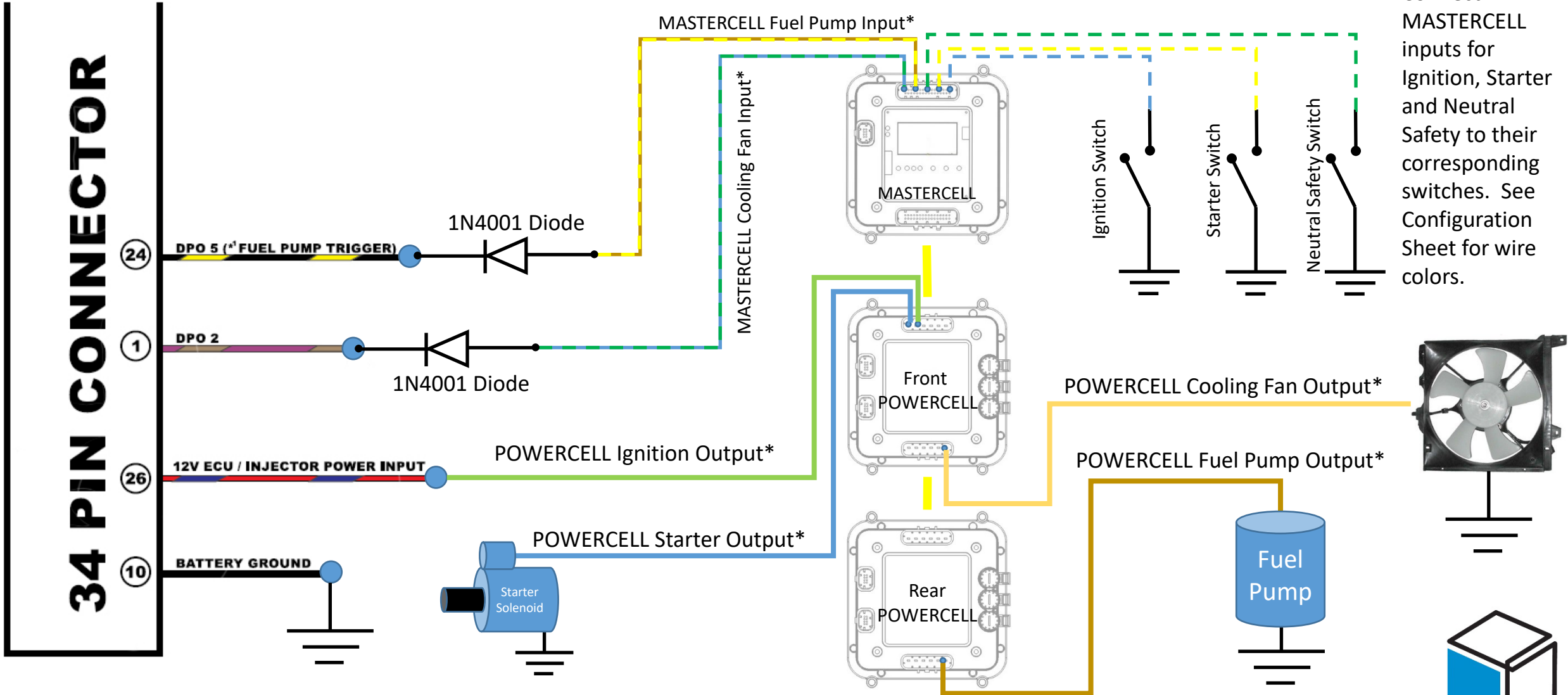

Connect MASTERCELL inputs for Ignition, Starter and Neutral Safety to their corresponding switches. See Configuration Sheet for wire colors.

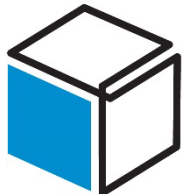

\*NOTE: Infinitybox wire Colors & Connector Positions will vary for different kits. See the Configuration Sheet that came with your kit for exact wire colors and locations.

## Wiring the Haltech Elite 950 ECU

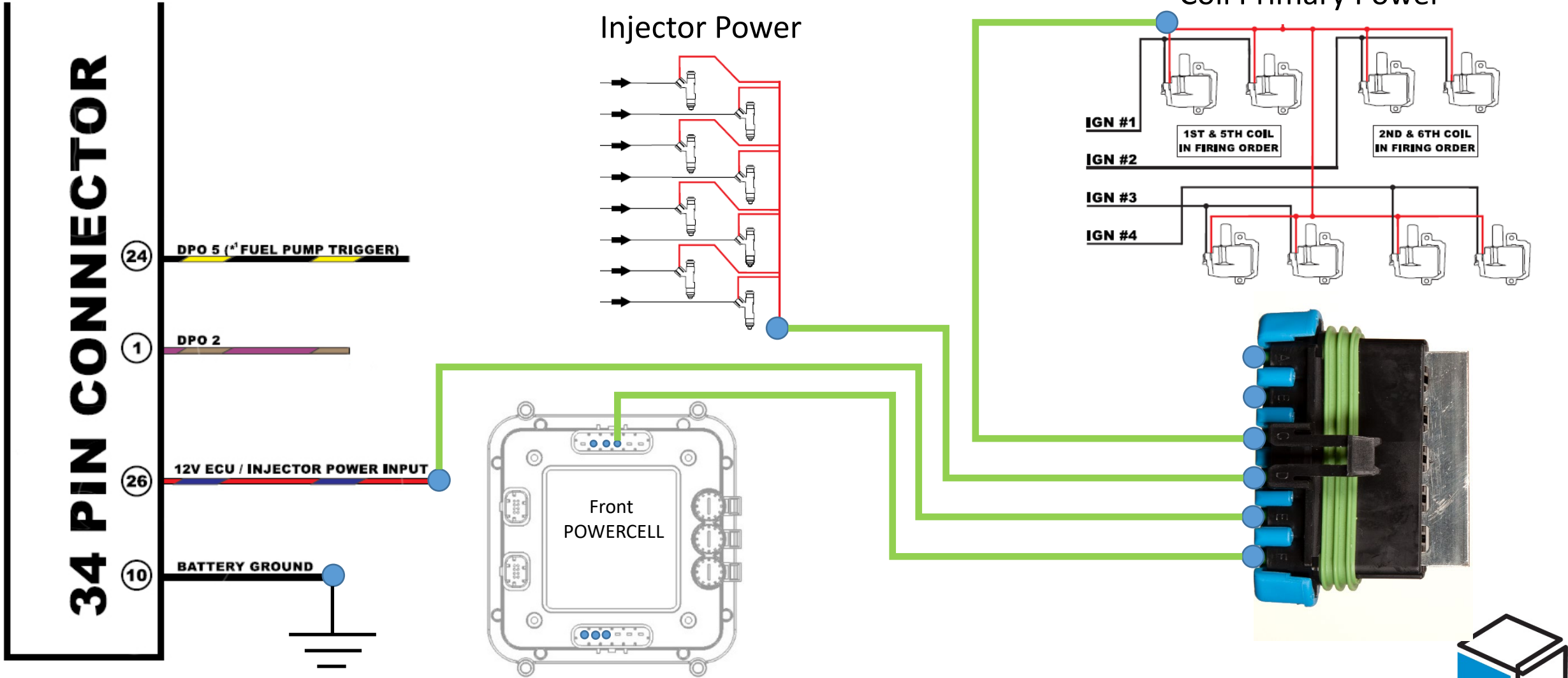

\*NOTE: Infinitybox wire Colors & Connector Positions will vary for different kits. See the Configuration Sheet that came with your kit for exact wire colors and locations. Some wires omitted for clarity. Follow the instructions that came with your kit for complete details.

